

# **R Series I Chiller**

## **Instantaneous Chiller**

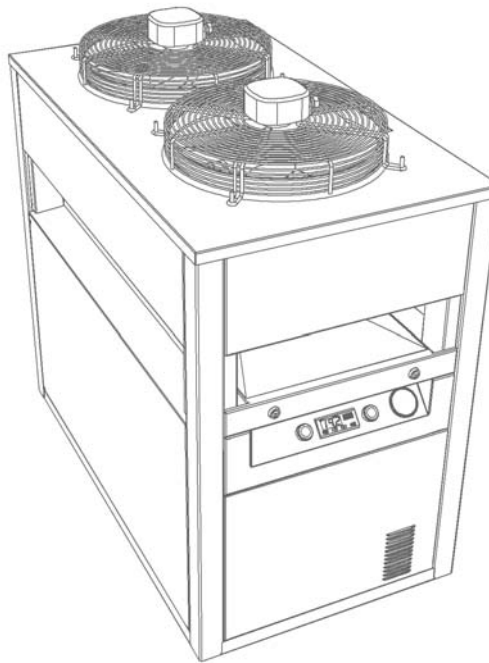

**The R Series I Instantaneous Chiller is designed for potable water applications where it is mandatory to ensure that a leak in the refrigeration circuit cannot contaminate the potable water supply.**

## QUICK START GUIDE

1. Find a suitable installation site
2. Organise electrician to run power to site and fit an isolating switch
3. Organise plumber to connect the water supply to the chiller and thence onto the point of consumption
4. Run through commissioning instructions

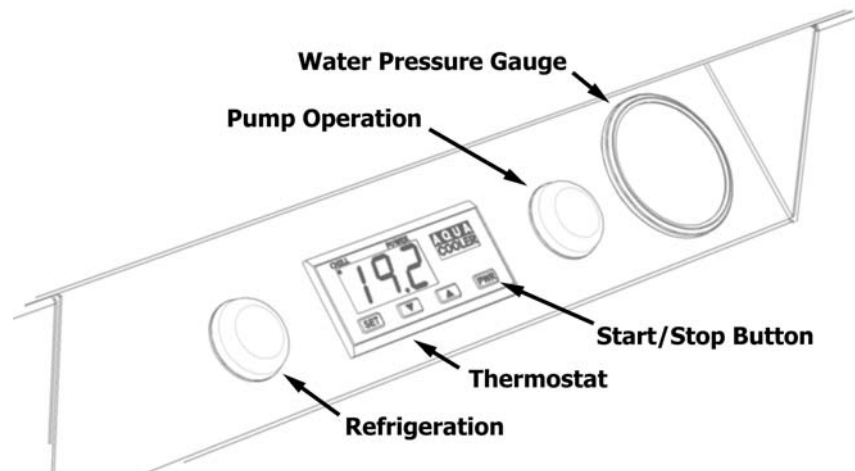

5. Press the "Start/Stop" button once to start moving process water around the pipe run
6. Press and hold the "SET" button on the thermostat, then press the up and down buttons to set the desired temperature

The refrigeration circuit will cut in and operate whenever the current water temperature within the buffer tank rises more than the hysteresis (factory set to 2K) above the set point temperature. Once the water temperature falls to the set point temperature the refrigeration circuit will automatically switch off. Hence if the set point is 5°C and the hysteresis remains factory set to 2K, then the chiller will cut in whenever the water temperature exceeds 7°C and cut out once it falls to 5°C.



## INDEX

QUICK START GUIDE .....	2
INDEX.....	3
GENERAL INFORMATION.....	4
Warranty.....	4
Service and spare parts .....	4
Safety.....	4
TECHNICAL DATA .....	5
INSTALLATION .....	7
Inspection .....	7
Positioning .....	7
Plumbing.....	7
Water treatment .....	8
Electrical connections .....	8
COMMISSIONING .....	9
OPERATION .....	10
Setting the thermostat.....	10
Starting the chiller.....	10
Operation indicators .....	10
MAINTENANCE .....	12
Cleaning The Condenser .....	12
Checking The Refrigerant Circuit .....	12
Refrigerant Pressure Settings .....	14
Checking The Water Circuit.....	14
Electrical .....	14
TROUBLESHOOTING .....	15
WIRING DIAGRAM – Single Phase Units.....	19
WIRING DIAGRAM – Three Phase Units .....	20



## **GENERAL INFORMATION**

### **WARRANTY**

We warrant to the original purchaser that the equipment offered is free from defects due to faulty workmanship or material, for a period of 12 months from the date of supply, fair wear and tear excepted. Our warranty does not imply a Guarantee. Warranties applying to items not of our manufacture are those warranties extended to us by the Manufacturers of the respective items.

### **SERVICE AND SPARE PARTS**

For all service and spare parts requirements within Australia please call Aqua Cooler on 1800 005 790.

Preventative maintenance programs carried out by trained refrigeration technicians are available from Aqua Cooler on request. These programs are designed to maximise the operational life of the chiller and to pre-emptively address any service problems that may arise. For further details contact Aqua Cooler.

For total peace of mind Aqua Cooler offers fixed term service contract that ensures trained service technicians are on call to address any problems that may occur with the chiller. This service encompasses the benefits of our preventative maintenance program, as well as ensuring that your service agent is supplied with a range of common spare parts to facilitate any repairs that may be necessary. To minimise your exposure to the costs carried due to equipment failure ask Aqua Cooler for full details on our service contracts.

### **SAFETY**

This chiller was designed to be safe in the use for which it was planned provided that it is installed, started up and maintained in accordance with the instructions contained in this manual. The chiller contains electrical components that operate at line voltage, and contains moving parts. It therefore must be isolated from electrical supply before being worked on. All maintenance operations that require access to the chiller must be carried out by suitably qualified operators who have a thorough understanding of all necessary precautions associated with refrigeration machinery.

The liquids to be cooled must be compatible to the materials used in the construction of this chiller. These liquids can be water, or mixtures of water and glycol for example. The liquids to be cooled must not be flammable.

Keep the chiller clean at all times. Protect components by covering them with clean tap or cloth during maintenance or repair work. Do not use flammable liquids to clean any components during operation.

All guards must be reinstalled after carrying out any repair of maintenance work.

This chiller contains refrigerant under pressure. If the chiller is no longer required it is essential to reclaim the refrigerant from the unit prior to disposal. A suitably qualified refrigeration mechanic should be engaged to perform this task.

## TECHNICAL DATA

		R150A	R180A	R230A	R300A	R330A
Compressor horsepower	hp	1.5	1.8	2.3	3.0	3.3
Cooling Capacity for 2°C <sup>1</sup> Outlet Water <sup>2</sup>	kW	1.3	1.9	3.1	4.0	4.5
Cooling Capacity for 5°C Outlet Water	kW	1.6	2.4	3.7	4.7	5.4
Cooling Capacity for 10°C Outlet Water	kW	1.8	2.8	4.2	5.4	6.4
Cooling Capacity for 15°C Outlet Water	kW	2.4	3.6	5.3	6.7	8.0
Inertia Tank Capacity	L	80				
Dry Weight	Kg	160		170	180	
Power Requirements – Single Phase		240V 50Hz Single Phase			Not Readily Available In Single Phase	
Maximum Current Draw - Single Phase <sup>3</sup>	A	12.6	14.5	19.6		
Power Requirements – Three Phase		415V 50Hz 3 Phase plus Neutral (4A Max)				
Maximum Current Draw - Three Phase	A/phase	5.9	6.6	8.2	9.6	10.4

To correctly size a chiller for your application utilise this formula as a guide:

Example: Cooling 3L/min of potable water from 20°C down to 5°C

$$\text{Required Cooling Capacity (kW)} = C_p \times \Delta T \times \text{Flow Rate}$$

$C_p$  = Specific Heat Of Fluid Being Cooled in kJ/kg.K (~ 4.2kJ/kg.K for water)

$\Delta T$  = The difference between the inlet and outlet temperatures

Flow Rate = Desired flow rate in kg/s (assume 1 kg/s = 1 L/s)

$$\begin{aligned} \text{Required Cooling Capacity (kW)} &= C_p \times \Delta T \times \text{Flow Rate} \\ &= 4.2\text{kJ/kg.K} \times (20-5)\text{K} \times (3/60)\text{kg/s} \\ &= 3.15\text{kW} \end{aligned}$$

From the table above an R230A will be sufficient for this application, with a cooling capacity of 3.7kW at an outlet water temperature of 5°C

<sup>1</sup> For supply temperatures below 4°C it is mandatory to ensure a suitable antifreeze is added to the chillers inertia tank.

<sup>2</sup> Based on operation within a 45°C ambient environment. Increase cooling capacity by 20% for operation within 35°C environment

<sup>3</sup> Maximum current draw based on outlet water temperature not exceeding 20°C when operating within 45°C ambient environment

### Overall Sizes, Plumbing & Electrical Connections

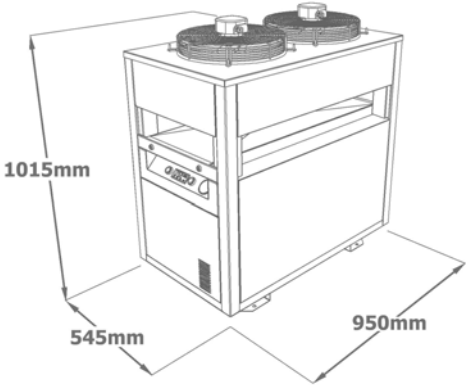
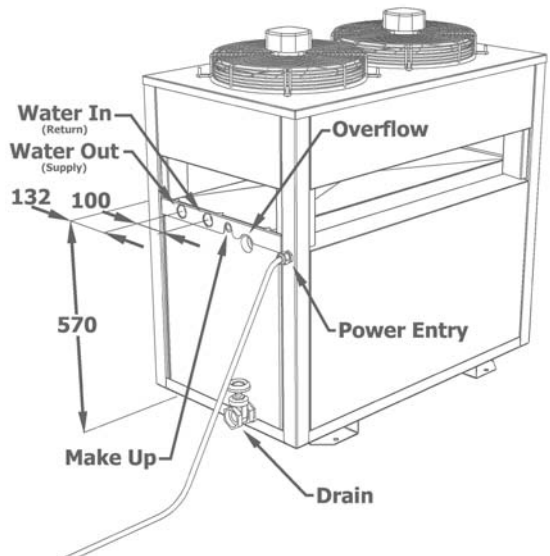
	<p>Water In Connection: 1" BSP (DN25)</p> <p>Water Out Connection: 1" BSP (DN25)</p> <p>Make Up Water Connection: 3/8" BSP</p> <p>Overflow: 1 1/4" BSP</p> <p>Drain (Gate Valve Factory Fitted): 1 1/4" BSP</p> <p>Power Entry Point: M25 x 1.5mm Thread</p>	
---	--	---

### Specifying An R Series Chiller

<p style="text-align: center;"><b>R 230 AQ 3 - P1F - CTC</b></p> <div style="display: flex; justify-content: space-around;"> <div style="text-align: left;"> <p><b>Capacity</b></p> <ul style="list-style-type: none"> <li>150</li> <li>180</li> <li>230</li> <li>300</li> <li>330</li> </ul> </div> <div style="text-align: left;"> <p><b>Condenser</b></p> <ul style="list-style-type: none"> <li>A</li> <li>AQ</li> <li>AR</li> <li>W</li> </ul> </div> <div style="text-align: left;"> <p><b>Power</b></p> <ul style="list-style-type: none"> <li>1</li> <li>3</li> </ul> </div> <div style="text-align: left;"> <p><b>Process Supply</b></p> <ul style="list-style-type: none"> <li>P1</li> <li>P2</li> <li>P3</li> <li>I</li> </ul> </div> <div style="text-align: left;"> <p><b>Application</b></p> <ul style="list-style-type: none"> <li>CT</li> <li>RC</li> <li>C</li> </ul> </div> </div>	<ul style="list-style-type: none"> <li><b>A</b> Air Cooled Condenser</li> <li><b>AQ</b> Quiet Format Air Cooled Condenser</li> <li><b>AR</b> Remote Air Cooled Condenser</li> <li><b>P1</b> Process Pump Style 1</li> <li><b>P2</b> Process Pump Style 2</li> <li><b>P3</b> Process Pump Style 3</li> <li><b>I</b> Instantaneous Chiller</li> <li><b>F</b> Flow Control</li> <li><b>CT</b> Close Tolerance</li> <li><b>RC</b> Microprocessor Control</li> <li><b>C</b> Castors</li> </ul>
--	---

## INSTALLATION

### INSPECTION

Immediately upon receipt of the chiller, carefully inspect it for any damage that may have occurred in transit. Any such damage must be noted on the carrier's delivery documents. It is the consignee's responsibility to make any subsequent claims upon the carrier or the respective insurance company.

### POSITIONING

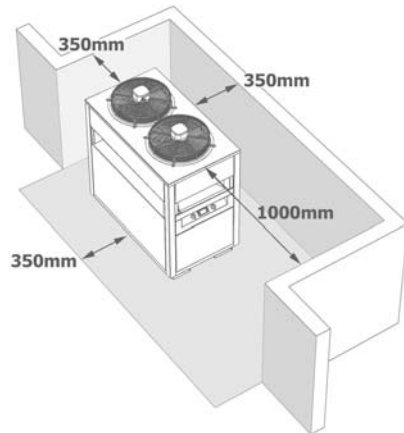

This chiller has been designed for installation in outdoor locations, but may be installed indoors provided there is sufficient ventilation to prevent re-circulation of air through the condenser.

When installing indoors it is important to understand that the chiller will impart a significant heat load into the environment and it is essential to ensure a plentiful, unrestricted supply of ambient temperature air to

the chiller. Should you have concerns over the installation site then please contact Aqua Cooler for advice.

***Under no circumstances is ducting to be attached to the condenser fan outlets.***

This chiller has been designed to draw air from each side and to exhaust vertically through the top of the unit. Preferably there should be no obstructions above the chiller, with a minimum of one metre clearance permitted in other circumstances. In addition to ensuring sufficient space

around the chiller for free air movement, provision must be made around the chiller for service and regular maintenance.

The chiller must be installed on a firm and level foundation, of adequate strength to support the chiller's full operating weight. Vibration isolation, such as rubber waffle pads, should be installed between the chiller and the supporting structure.

The chiller should not be located where it is subjected to roof drainage and must be located above ground level in areas that are prone to stormwater flooding.

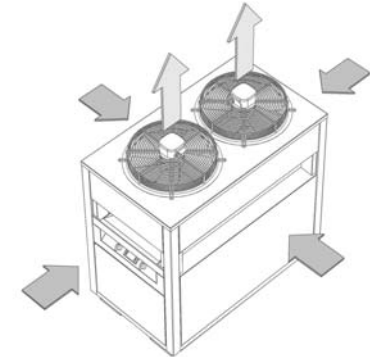

***It is essential to ensure that adequate and safe service access to the chiller is provided. Failure to provide safe access to the chiller may lead to additional charges should servicing be required.***

### PLUMBING

***The chilled water supply and return connections are supplied with 1" BSP union connectors which have been fitted to facilitate access to the chiller should servicing be required.***

This chiller can be utilised to either chill water supplied directly from a mains pressure supply, or to chill re-circulated water.

***If re-circulating water through the chiller ensure that a suitable strainer or filter is installed prior to the return water connection to prevent inadvertent blockage of the chillers heat exchanger. Failure to do so will void warranty.***

All piping running to and from the chiller should be well insulated with a water resistant material to prevent the formation of condensation and to maximise the cooling capacity of the chiller.

# AQUA COOLER

It is recommended that the following components be installed in the plumbing to ensure trouble free operation and to permit convenient access for identification of flow related problems should they occur.

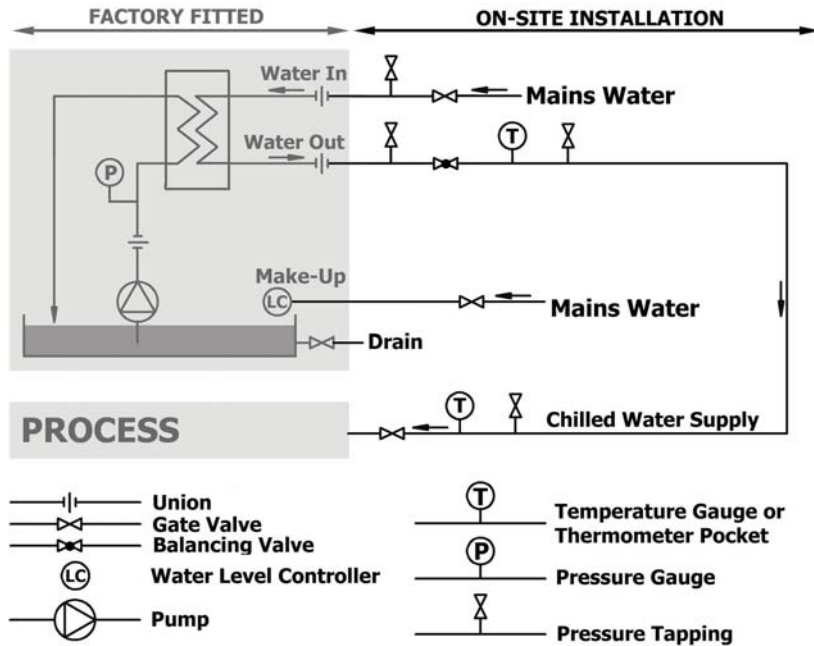

## WATER TREATMENT

Water treatment for the chiller's internal inertia tank should be considered in order to ensure overall water quality is maintained in terms of pH, Calcium content, Alkalinity, Ionic strength of water etc.

Most scaling is either due to calcium carbonate or calcium sulphate precipitation. Certain inorganic salts, most notably calcium sulphate (CaSO<sub>4</sub>) have an inverted solubility curve (solubility in water decreases with increasing temperature).

The pH level of the inertia tank water should be monitored and maintained

at between 6.5 and 8.5. At high pH values the scaling tendency is increased.

Ethylene glycol should be added if the system is run with water temperatures below 4°C, or if ambient conditions around the chiller can fall to sub zero temperatures.

It is important to ensure that any water treatment is passive to the wetted materials used in the construction of the chiller, which include:

- Stainless Steel
- High Density Polyethylene
- Brass
- Copper

## ELECTRICAL CONNECTIONS

***The connection of the unit to the power network must be carried out in accordance with local supply authority regulations by a competent licensed electrician.***

A suitable weatherproof isolating switch should be mounted close to the chiller into which the chiller's power cable can be terminated. Ensure that the cable run from the chiller to the isolating switch does not exceed the 5 metre cable length factory fitted to the chiller.

Power cables must be adequately protected against mechanical damage. Conduit can be installed to the chiller by removing the power cable gland fitted at the point where the power cable enters the chiller and replacing it with a suitable M25 cable conduit termination gland.

Mains supply cables must be sized to ensure adequate voltage at the chiller under all load conditions. Three phase power must be symmetrical, ensuring equal effective voltage and equal phase angles between consecutive phases.

***Ensure all electrical connections are tight prior to start-up as during transit some connections may have vibrated loose.***

***Power should be supplied to the unit at least three hours prior to start up to ensure that the sump heater will boil off any refrigerant in the compressor oil.***



## **COMMISSIONING**

A comprehensive commissioning program carried out by qualified refrigeration mechanics is available through Aqua Cooler. Benefits of this service include extended warranty. For full details and conditions please contact Aqua Cooler.

- Before the chiller can be started it is essential that the water circuit is complete and ready for operation.
- Ensure that clearances around the chiller meet with minimum requirements specified.
- Ensure that the chiller is connected to a suitable isolating switch and that an adequate circuit breaker or fuse is installed at the switchboard.
- Ensure that all electrical connections and terminals are tight.
- Check the supply voltage to the chiller and ensure it is within the required limits specified on the wiring diagram.
- Supply power to the chiller – Power should be supplied for at least three hours prior to starting the compressor in order to ensure that the compressors sump heater can boil off any liquid refrigerant that may have migrated to the compressor's sump.
- Remove the tank cover and confirm that the tank is empty and that any packing material around the evaporator has been removed.
- Clean all surfaces and remove all litter.
- Prior to filling the tank open the drain valve to permit and any foreign material to be flushed from the tank. Ensure that all pipework has been flushed to ensure that it is thoroughly clean.
- Close the drain valve on the tank and permit water to enter the tank through the make up valve.
- Check the entire water circuit for leaks and add in water treatment should this be required.
- Turn on the chiller by pressing the PWR button – the compressor should cut in immediately. Check for any unusual noises or vibration.

Check that the compressor does not cutout prior to water temperature reaching the set point. If the water temperature at start-up is above 30°C then there is a chance that the high pressure safety circuit may cut in to prevent damage to the compressor. If this does occur wait for 5 minutes then reset the high pressure safety switch per instructions.

- Adjust the water temperature set point to the desired value.

## OPERATION

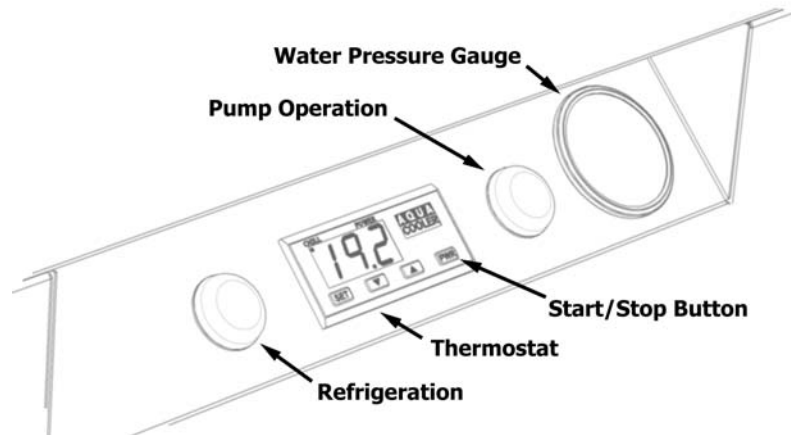

**Warning:** Ensure that the requirements listed in the **INSTALLATION** and **COMMISSIONING** sections have been followed prior to operating the chiller.

**Warning:** Ensure all operators have read and understood the **SAFETY** section of this manual prior to operating the chiller.

**Warning:** Do not turn off the chiller at the isolating switch as this will isolate the compressor sump heater and may lead to irreparable compressor damage upon restart.

### SETTING THE THERMOSTAT

- Press and hold the **SET** button on the thermostat – the set temperature will then be displayed
- Press the up ▲ or down ▼ button until the desired set point has been reached
- Release the **SET** button

### STARTING THE CHILLER

- To start the chiller press the **PWR** button mounted on the thermostat.
- To stop the chiller press the **PWR** button again

### OPERATION INDICATORS

The chiller is provided with a number of visual indicators that clearly detail operation of the chiller. In the event of a problem these indicators can be used to locate the source of a problem. For detailed instructions refer to the **TROUBLESHOOTING** guide within this manual.

- Refrigeration Indicator ➔ Illuminated whenever the refrigeration circuit is called upon to operate
- Pump Indicator ➔ Illuminated whenever the pump is operational
- Water Pressure Gauge ➔ Details the available pressure head being supplied by the pump
- Thermostat Display ➔ Indicates the current water temperature and provides status lights on refrigeration

**CHILL Indicator** - Illuminated whenever the thermostat calculates that refrigeration is required to lower the water temperature

**POWER Indicator** - Illuminated whenever the chiller is running

**Display** - Details current temperature, temperature set-point and thermostat fault conditions

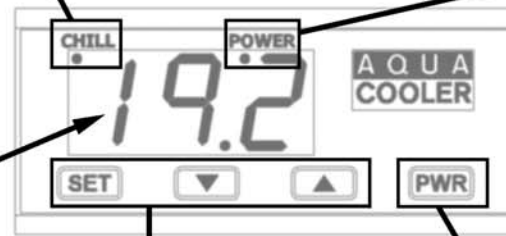

**Power Button** - Used to START/STOP the chiller

**Set-Point Buttons** - Used for establishing the temperature set-point

**Note:** Should the thermostat display a code other than a temperature reading then consult the troubleshooting guide for advise.

**Note:** After a loss in power the chiller we restart automatically if it was on immediately prior to the loss in power.

**Note:** This chiller is factory set to operate on a 2°C hysteresis. Please consult Aqua Cooler should you wish to alter this setting.

**MAINTENANCE**

**Warning:** *Isolate the power from the unit prior to working on the chiller.*

**Warning:** *Ensure that all personnel have read and understood the SAFETY section of this manual prior to working on the chiller.*

These units have been purposely designed for a minimum of maintenance. However, to ensure optimum performance, qualified personnel should carry out regular maintenance. A comprehensive preventative maintenance program carried out by qualified refrigeration mechanics is available through Aqua Cooler. For full details and conditions please contact Aqua Cooler.

**Should any faults be identified then please contact Aqua Cooler to arrange for a service call.**

Recommended Preventative Maintenance Program:

Operation	Frequency
Clean Condenser Coil	6 monthly
Check For Evidence Of Moisture In Refrigerant	6 monthly
Check For Refrigerant Blockages	6 monthly
Check For Evidence Of Refrigerant Leaks	6 monthly
Check Refrigerant Operating Pressures	6 monthly
Check Flow Rates & Pressure Drops In Water Circuit	6 monthly
Check For Integrity Of Electrical Connections	6 monthly
Check Current Draw On All Motors	12 monthly
Clean Out Buffer Tank	12 monthly

**CLEANING THE CONDENSER**

Ensure that the finned condenser coil is kept clean at all times. This may be accomplished using compressed air or any appropriate bottled inert gas. Care must be taken not to damage the aluminium fins. For full access to the condenser fins remove the side panels as shown in the following figure. For a thorough cleansing, use a mild detergent to clean the condenser fins. Ensure the panels are replaced once the task has been completed

**Warning:** *Ensure electrical power to the chiller is isolated whenever the condenser side panels have been removed.*



**CHECKING THE REFRIGERANT CIRCUIT**

The refrigeration circuit is hermetically sealed and should require no regular maintenance. However, to ensure that the integrity of the circuit

# AQUA COOLER

has not been compromised a number of simple checks can be performed. Firstly remove the tank cover via the two fast release catches on the front face. Turn off the process pump and allow the water in the buffer tank to settle. Check for evidence of gas bubbles rising from the evaporator.

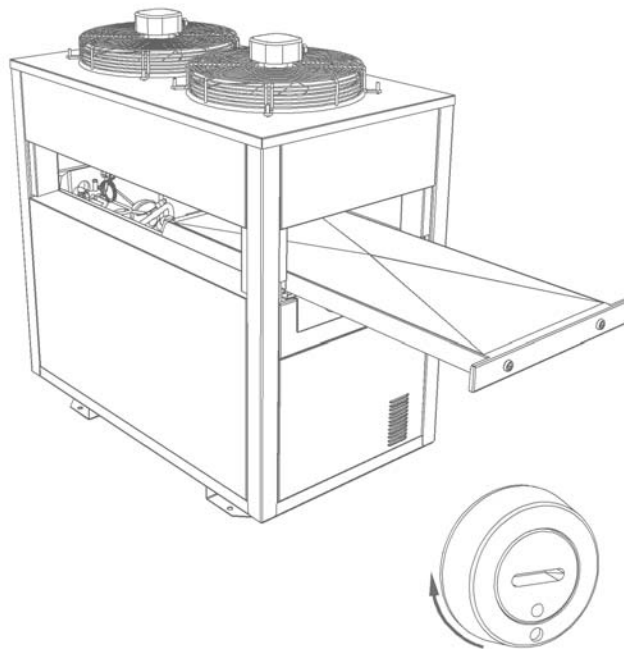

Remove the front access panel beneath the electrical enclosure and the left hand side cover and inspect the refrigerant sight glass for signs of moisture. A coloured tag within the sight glass will clearly show if moisture is present in the system.

## Manufacturing In Australia Since 1946

With the compressor operating check that the sight glass is full of liquid. A small stream of bubbles is acceptable, but anything more may indicate a loss in refrigerant charge.

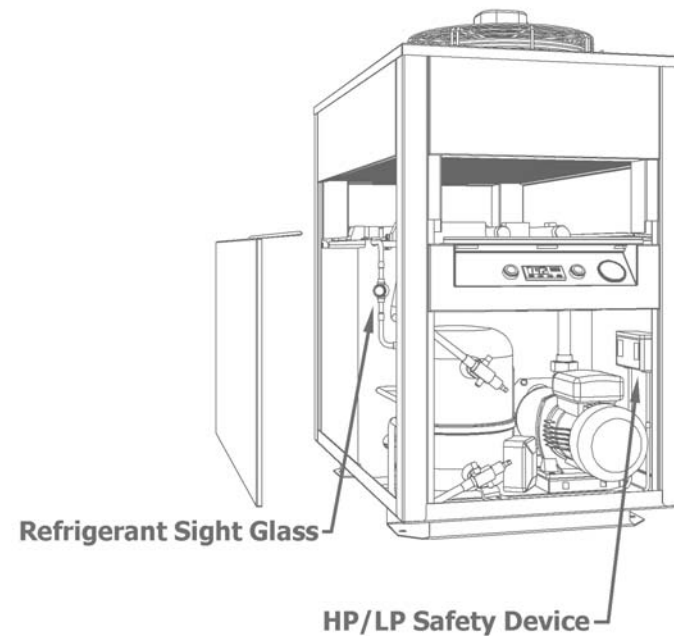

Check whether a marked temperature difference is evident across the refrigerant drier, which is located adjacent to the refrigerant sight glass. A significant temperature difference is an indicator that the drier is blocked. Look for evidence of oil around refrigerant fittings as this is a clear indicator of a leak.

Confirm that no refrigerant pipes are rubbing against each or anything else as this may lead to a refrigerant pipe rupture.

## REFRIGERANT PRESSURE SETTINGS

This chiller is fitted with HP/LP safety device located just inside the front access panel as shown in the previous diagram. The high pressure (HP) cutout has a manual reset via a green reset switch located on top of the device. The HP cut out is designed to prevent excessive refrigerant pressures building up inside of the unit which would generally only occur if the condenser is partially blocked, ambient temperatures are exceedingly high, a condenser fan has failed, or there is a blockage in the refrigerant circuit.

In the event of the high pressure cut out activating try and rectify the root cause of the high pressure and then reset the HP/LP device by pushing the green reset button.

This low pressure (LP) cutout automatically resets. The LP cut out is designed to ensure that the pressure in then refrigerant circuit exceeds ambient conditions at all times, thus preventing the compressor sucking in moisture laden air, or worse still, liquid water in the event of a leak.

The only other pressure control is used to cycle the second fan on and off in order to maintain optimal refrigerant pressures in the circuit.

Factory pressure control settings are:

Pressure Control	Setting
High Pressure Cut Out	2800kPa
Low Pressure Cut In	410kPa
Low Pressure Cut Out Differential	240kPa
Low Pressure Cut Out Point (Cut In - Differential)	(170kPa)
Fan Cycle Cut In	1640kPa
Fan Cycle Cut Out	1240kPa

## CHECKING THE WATER CIRCUIT

Check the flow rate and supply pressure being delivered to the process to ensure than they have not deteriorated. If they have consider back flushing the chiller with hot water to ensure that the internal heat exchanger is completely clean.

If the water supplied is very hard (high concentration of carbonates,

calcium and magnesium salts) then de-scale the internal surfaces of the water pipes and fittings with a suitable chemical ensuring it does not react with the materials directly in contact with the cooling water.

Component	Material(s)
Evaporator/Water Pipes	Copper
Inertia Tank	HDPE
Pump	Stainless Steel
Distributor/Connections	Brass
Heat Exchanger	Copper Brazed Stainless Steel

The inertia tank is fitted with a drain valve that can be opened to flush out contaminated water or sludge that may have accumulated in the inertia tank sump.

This chiller is exceedingly tolerant of contaminants within the water circuit, but none the less it is recommended that a cooling water sample be analysed annually to check for adverse conditions that may reduce the service life of the chiller.

It is recommended that the internal heat exch

## ELECTRICAL

**Note: The electrical circuit should only be inspected and serviced by a qualified refrigeration mechanic or electrician.**

Remove the cover over the electrical enclosure and clean out any dust or contaminants that may have accumulated within. Check that all screw terminals are tight. Monitor fan, pump and compressor current draws and check them against the ratings detailed in the wiring diagram at the end of this manual.

## TROUBLESHOOTING

Problem	Likely Cause(s)	Symptom	Remedy
Water temperature exceeds set point and compressor does not operate, but pump remains operating	Ambient temperature too high	<ul style="list-style-type: none"> <li>Chill indicator on thermostat illuminated but refrigeration indicator remains off</li> <li>Ambient temperature exceeds permissible limits at point of installation (Refer Technical Data)</li> </ul>	<ul style="list-style-type: none"> <li>Reset high pressure safety switch</li> <li>Consider relocating the chiller to a cooler environment</li> </ul>
	Condenser fins dirty or blocked	<ul style="list-style-type: none"> <li>Chill indicator on thermostat illuminated but refrigeration indicator remains off</li> <li>Ambient temperature does not exceed permissible limits at point of installation (Refer Technical Data)</li> </ul>	<ul style="list-style-type: none"> <li>Clean condenser fins per maintenance instructions</li> <li>Ensure there are no obstructions around the condenser per the installation instructions</li> <li>Reset high pressure safety switch</li> </ul>
	Air flow through condenser obstructed or warm air re-circulating through condenser		
	Front fan failed	<ul style="list-style-type: none"> <li>Chill indicator on thermostat illuminated but refrigeration indicator remains off</li> <li>Resetting the high pressure safety switch starts unit running but front fan does not operate</li> </ul>	<ul style="list-style-type: none"> <li>Call 1800 005 790 to organise for a replacement fan and if necessary a service technician to fit it</li> </ul>
	Fan overload(s) tripped (Automatically Reset)	<ul style="list-style-type: none"> <li>Chill indicator on thermostat illuminated but refrigeration indicator remains off</li> <li>Resetting the high pressure safety switch starts unit running but fans do not operate</li> </ul>	<ul style="list-style-type: none"> <li>Wait for fan internal thermal overloads to reset as fans cool down</li> <li>Call 1800 005 790 to organise for a service technician to inspect the fan(s) for damage and to replace if necessary</li> </ul>

	Fan cycle switch or rear fan failed	<ul style="list-style-type: none"> <li>• Chill indicator on thermostat illuminated but refrigeration indicator remains off</li> <li>• Resetting the high pressure safety switch starts unit running with front fan does operating but rear fan does not operate before high pressure safety switch trips</li> </ul>	<ul style="list-style-type: none"> <li>• Call 1800 005 790 to organise for a service technician to isolate fault and replace faulty component</li> </ul>
	Compressor thermal overload tripped	<ul style="list-style-type: none"> <li>• Both chill indicator on thermostat and refrigeration indicator are illuminated but compressor does not run</li> <li>• Resetting the thermal overload starts the compressor operating</li> </ul>	<ul style="list-style-type: none"> <li>• Call 1800 005 790 to organise for a service technician to inspect the compressor for damage and to replace it if necessary</li> </ul>
	Compressor contactor failed	<ul style="list-style-type: none"> <li>• Both chill indicator on thermostat and refrigeration indicator are illuminated but compressor does not run</li> <li>• Resetting the thermal overload does not start the compressor operating</li> </ul>	<ul style="list-style-type: none"> <li>• Call 1800 005 790 to organise for a replacement contactor and if necessary a service technician to install it</li> </ul>
	Heavy loss in refrigerant	<ul style="list-style-type: none"> <li>• Chill indicator on thermostat illuminated but refrigeration indicator remains off</li> <li>• Resetting the high pressure safety switch does not start the compressor operating</li> </ul>	<ul style="list-style-type: none"> <li>• Call 1800 005 790 to organise for a service technician to check for leaks and to eliminate them before replenishing refrigerant charge</li> </ul>
	Heat load too high for chiller	<ul style="list-style-type: none"> <li>• Water temperature exceeds 30°C</li> <li>• Resetting the high pressure safety switch starts unit running but unit cuts out before water temperature comes down</li> </ul>	<ul style="list-style-type: none"> <li>• Reduce the heat load to within limits specified in technical data</li> <li>• Allow water temperature to fall before restarting unit</li> </ul>

Water temperature exceeds set point and compressor operates intermittently, but pump operates continuously	Heavy loss in refrigerant	<ul style="list-style-type: none"> <li>Compressor operates intermittently</li> <li>Chill indicator on thermostat continuously illuminated but refrigeration indicator illuminates intermittently with compressor</li> <li>A lot of bubbles evident in the liquid sight glass</li> </ul>	<ul style="list-style-type: none"> <li>Call 1800 005 790 to organise for a service technician to check for leaks and to eliminate them before replenishing refrigerant charge</li> </ul>
	Low water level	<ul style="list-style-type: none"> <li>Make up valve continuously adding water to the tank</li> </ul>	<ul style="list-style-type: none"> <li>Check chilled water circuit for leaks</li> </ul>
Water temperature exceeds set point despite compressor continually operating	Heat load too high for chiller	<ul style="list-style-type: none"> <li>Few if any bubbles evident in the liquid sight glass whilst the compressor is operating</li> </ul>	<ul style="list-style-type: none"> <li>Reduce the heat load to within limits specified in technical data</li> <li>Allow water temperature to fall before restarting unit</li> </ul>
	Loss in refrigerant charge – insufficient refrigerant entering evaporator	<ul style="list-style-type: none"> <li>A lot of bubbles evident in the liquid sight glass whilst the compressor is operating</li> </ul>	<ul style="list-style-type: none"> <li>Call 1800 005 790 to organise for a service technician to check for leaks and to eliminate them before replenishing refrigerant charge</li> </ul>
Water temperature exceeds set point and neither compressor or pump are operating	Pump contactor failed	<ul style="list-style-type: none"> <li>Power light on thermostat is illuminated</li> <li>Pump indicator is illuminated</li> <li>Chill indicator on thermostat illuminated but refrigeration indicator remains off</li> </ul>	<ul style="list-style-type: none"> <li>Call 1800 005 790 to organise for a replacement contactor and if necessary a service technician to install it</li> </ul>
Water temperature below set point	Low water level in tank – temperature sensor not submerged	<ul style="list-style-type: none"> <li>Make up valve continuously adding water to the tank</li> <li>Ice formation over evaporator</li> </ul>	<ul style="list-style-type: none"> <li>Check chilled water circuit for leaks</li> </ul>
	Low water level in tank – temperature sensor not submerged	<ul style="list-style-type: none"> <li>Make up valve not adding water to the buffer tank</li> <li>Ice formation over evaporator</li> </ul>	<ul style="list-style-type: none"> <li>Check chilled water circuit for leaks</li> <li>Check supply of mains pressure water to make up valve</li> <li>If necessary call 1800 005 790 to organise for a replacement make up valve and a technician to install it if necessary</li> </ul>

	Thermostat failure	<ul style="list-style-type: none"> <li>• Temperature display either not operational or random</li> </ul>	<ul style="list-style-type: none"> <li>• Call 1800 005 790 to organise for a replacement thermostat and a technician to install it if necessary</li> </ul>
Process overheating despite chilled water temperature being within acceptable range	Excessive pressure drop in system – reduced flow to process	<ul style="list-style-type: none"> <li>• Water pressure gauge indicates peak pressure for pump as detailed in technical data</li> </ul>	<ul style="list-style-type: none"> <li>• Inspect the chilled water circuit for obstructions or scale build-up within pipe work</li> </ul>
	Bypass fully open – reduced flow to process	<ul style="list-style-type: none"> <li>• Water pressure gauge does not indicate peak pressure for pump as detailed in technical data</li> </ul>	<ul style="list-style-type: none"> <li>• Slowly close bypass valve until acceptable flow realised</li> </ul>
	Pump Overload Tripped (Automatically Resets)	<ul style="list-style-type: none"> <li>• Pump Indicator Illuminated</li> <li>• Water pressure gauge indicates no pressure</li> <li>• After a while the pump starts running again</li> </ul>	<ul style="list-style-type: none"> <li>• Call 1800 005 790 to organise for a service technician to inspect the pump for damage and to replace it if necessary</li> </ul>
Error message “E1” flashing on thermostat	Temperature sensor damaged	<ul style="list-style-type: none"> <li>• Pump continues to operate</li> </ul>	<ul style="list-style-type: none"> <li>• Call 1800 005 790 to organise for a replacement temperature sensor and a technician to install it if necessary</li> </ul>
Message “DF” on thermostat	Set point button ▲ and ▼ have been pressed simultaneously		<ul style="list-style-type: none"> <li>• Wait for 60 seconds for message to disappear</li> </ul>
No temperature display and all indicator lights are off, despite power being supplied to the unit	Control circuit breaker tripped		<ul style="list-style-type: none"> <li>• Call 1800 005 790 to organise for a service technician to inspect the electrical circuit for damaged components</li> </ul>

## WIRING DIAGRAM – SINGLE PHASE UNITS

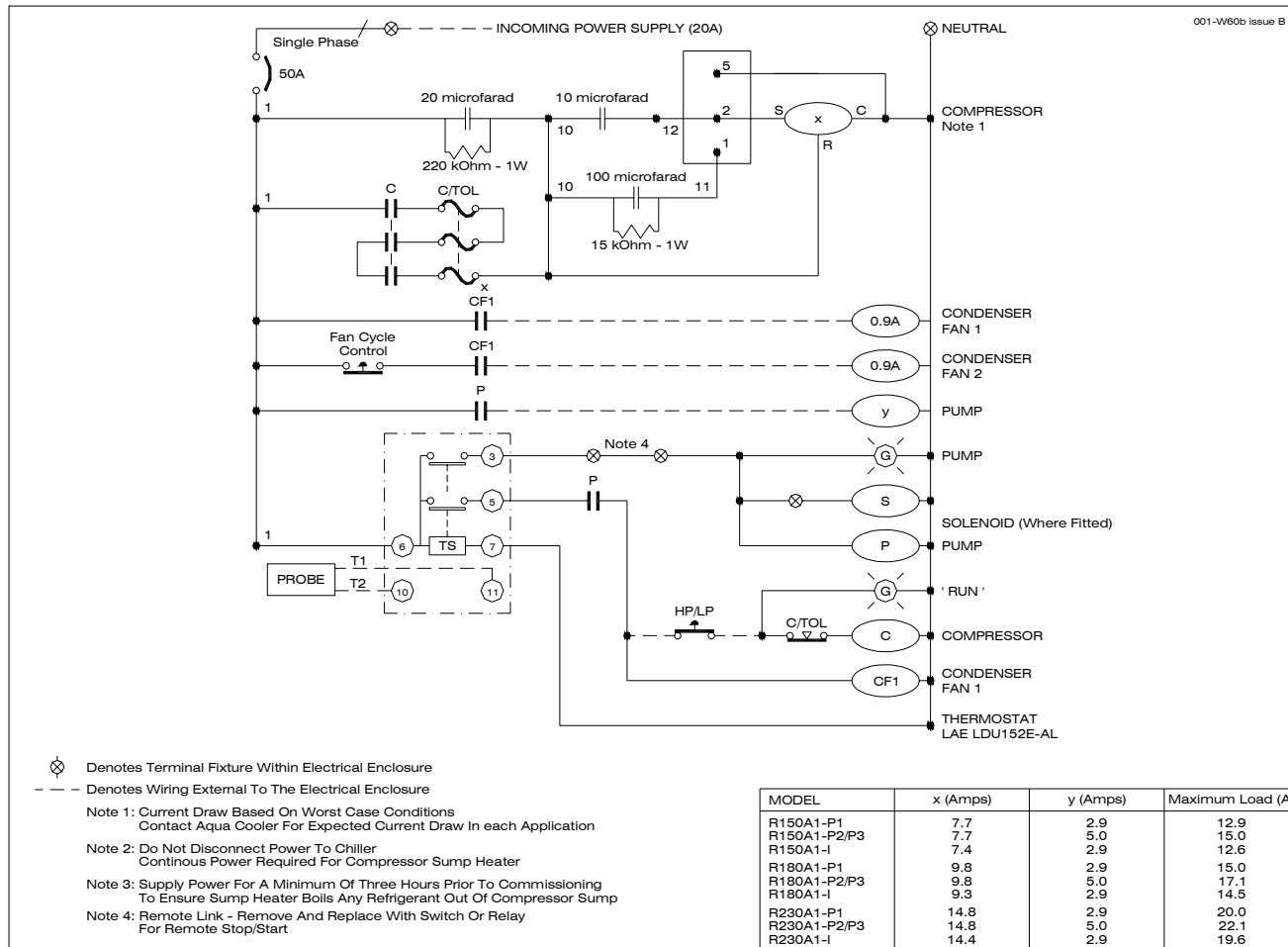

## WIRING DIAGRAM – THREE PHASE UNITS

