

# AQUA COOLER®

# WM SERIES



**WALL  
MOUNTED  
DRINKING  
WATER  
COOLER**

## MODELS

WM2 – BUBBLER ONLY

WM3 – BUBBLER & GLASS FILLER

## FEATURES

- Robust construction to ensure longevity
- Highly Polished stainless steel top
- Optional stainless steel cabinets
- Adjustable, tamper proof non-squirt bubbler and glass filler

PROUDLY AUSTRALIAN MADE

## CONTACT

AQUA COOLER PTY LIMITED  
161 ORCHARD ROAD  
CHESTER HILL NSW 2162 AUSTRALIA

TEL: (02) 9721 9333  
FAX: (02) 9721 9344

EMAIL: [sales@aquacooler.com.au](mailto:sales@aquacooler.com.au)  
[coolers@aquacooler.com.au](mailto:coolers@aquacooler.com.au)

DRINKING WATER ..... CHILLED TO PERFECTION  
Visit [www.aquacooler.com.au](http://www.aquacooler.com.au)

# AQUA COOLER®

### WATER RESERVOIR

A 0.5 litre tank is incorporated within the chilling chamber to meet peak usage periods. The tank is fabricated from seamless hard drawn copper which is tin plated for safety. The chilling capacity is 8 lph during peak periods.

### REFRIGERATION

The refrigeration system uses 170gms of R134a gas, which is non-toxic, non-flammable and environmentally friendly. The refrigerant is controlled by a capillary tube, which has no moving parts. The system is fitted with a suction line to give maximum heat exchange efficiency

### WATER FLOW CONTROL

The bubbler is rated to supply 1.7 litres per minute at any mains pressure between 140 and 700kPa. An automatic, self-regulating control is fitted to overcome varying mains pressure water.

### WATER CONNECTIONS

Water inlet – 1/2" female B.S.P.  
 Drain Outlet – 40mm Female F.P.V.C. pipe

### THERMOSTAT CONTROL

The thermostat is factory pre-set.

### COMPRESSORS

1/8 h.p. capacity, 90 watts.  
 The compressor is hermetically sealed for silent running.

### CONDENSER

The condenser is of copper tube and expanded aluminium fin.

### ELECTRICAL

240 volts, 50Hz. A 2 metre house cable and 3 pin plug is supplied.  
 Full load current is 1.06 amps.

### PERFORMANCE TO ARI 1010-94 STANDARD

Water Inlet – 26.7°C  
 Water Outlet – 10°C  
 Ambient Air – 32.2°C.

### WEIGHT – PACKED

31kgs

### DIMENSIONS – PACKED

30cm long x 30cm wide x 55cm high

### WARRANTY

Twelve months comprehensive coverage.  
 Five years for compressor replacement

### INSTALLATION NOTE

- There must be a minimum of 75mm on both sides of the cooler to facilitate air-flow.
- With water pressure above 700kPa a pressure reduction valve should be fitted.



**MAINS  
CONNECTED  
DRINKING  
WATER  
FOUNTAINS**

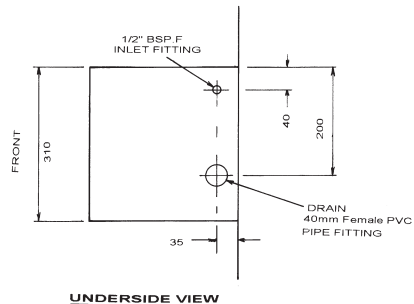
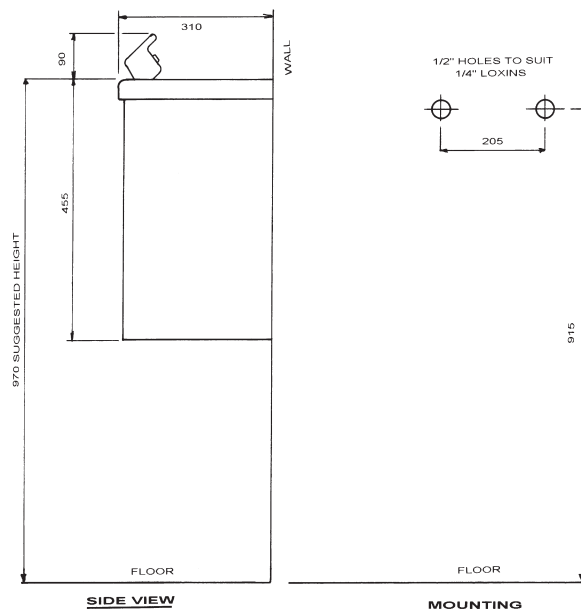

### DISTRIBUTED BY

### OTHER FEATURES

- For customer convenience the units can be mounted at various heights on a wall
- A versatile water cooler suitable for many applications
- Suitable for corridors where floor space is a premium